



IPE40

Datasheet

Version: 1.3
Date: 09/03/2017



Revision Overview

Date	Revision	Change(s)
15.02.2007	1.0	First Version
23.11.2010	1.1	Bugfix table 8
21.07.2011	1.2	Update
09/03/2017	1.3	change to new AMAC document layout

© Copyright 2018 AMAC ASIC- und Mikrosensoranwendung Chemnitz GmbH

Subject to change without prior notice.

Our policy is one of continuous improvement, and consequently the equipment may vary slightly from the description and specifications in this publication. The specifications, illustrations and descriptions provided in this documentation are not binding in detail. No part of this publication may be reproduced in any form, or by any means, without the prior written permission of AMAC ASIC- und Mikrosensoranwendung Chemnitz GmbH. All rights according to the law on copyright remain expressly reserved to AMAC ASIC- und Mikrosensoranwendung Chemnitz GmbH.

Table of Content

1 Features.....	6
2 Input Signals.....	7
3 Setting into Operation and Configuration.....	8
3.1 Meaning of the Connectors.....	8
3.2 Meaning of the Jumpers.....	8
3.3 Meaning of the Switches.....	8
4 Configuration of the Sensor Connection.....	8
4.1 Configuration of the Soldering Jumpers LJ1 – LJ6.....	8
4.2 Configuration of the Jumpers.....	9
5 Assignment and Adjustment of Operation – Modes.....	9
5.1 Switch S3 – Gain Selection.....	9
5.2 Switch S4 and S5 – Interpolation Rate and Reference Pulse Width.....	9
5.3 Hysteresis.....	10
6 Edge Distance Control.....	10
7 Connector Pinning.....	12
7.1 X10 – Measuring System Connector (Input) / X11 – Output RS422.....	12
8 Parameters.....	13
8.1 Operation Conditions.....	13
8.2 Parameters Interpolation.....	13
8.3 Parameter Configuration / Parameters Digital.....	13
9 Ordering Information.....	13
10 Component mounting diagram.....	14
10.1 Component side.....	14
10.2 Dimensions.....	14
11 Notes.....	15

List of Tables

Table 1: Characteristics IPE40.....	6
Table 2: Description Input Amplifiers.....	7
Table 3: Connectors.....	8
Table 4: Jumpers.....	8
Table 5: Switches.....	8
Table 6: Gain Selection.....	9
Table 7: Interpolation Rate and Reference Pulse Width.....	9
Table 8: Digital Hysteresis.....	10
Table 9: Edge Distance Control.....	11
Table 10: Signal input / Signal output.....	12
Table 11: Operation Conditions.....	13
Table 12: Parameters Interpolation.....	13
Table 13: Parameter Configuration / Parameters Digital.....	13
Table 14: Ordering Information.....	13

List of Figures

Figure 1: Block diagram.....	6
Figure 2: Input signals IPE40.....	7
Figure 3: Reference Point Comparator.....	7
Figure 4: Soldering Jumper 7.....	8
Figure 5: Digital Hysteresis.....	10
Figure 6: Minimum Edge Distance.....	10
Figure 7: Configuration A/B – edge distance.....	11
Figure 8: Dependence of the A/B – edge distance from the supply voltage.....	11
Figure 9: Component side.....	14
Figure 10: Dimensions.....	14

1 Features

The interpolation unit IPE40 is suitable for increasing the resolution of incremental position and angular measuring systems with sine shaped output signals. It can be used with the standard voltage signals as well as current signals. An adjustable minimum A/B – edge distance at the output and a programmable analogue and digital hysteresis enables also the use in case of noisy input signals. Due to its structure the unit can be plugged between measuring system and evaluation electronic easily.

Block diagram

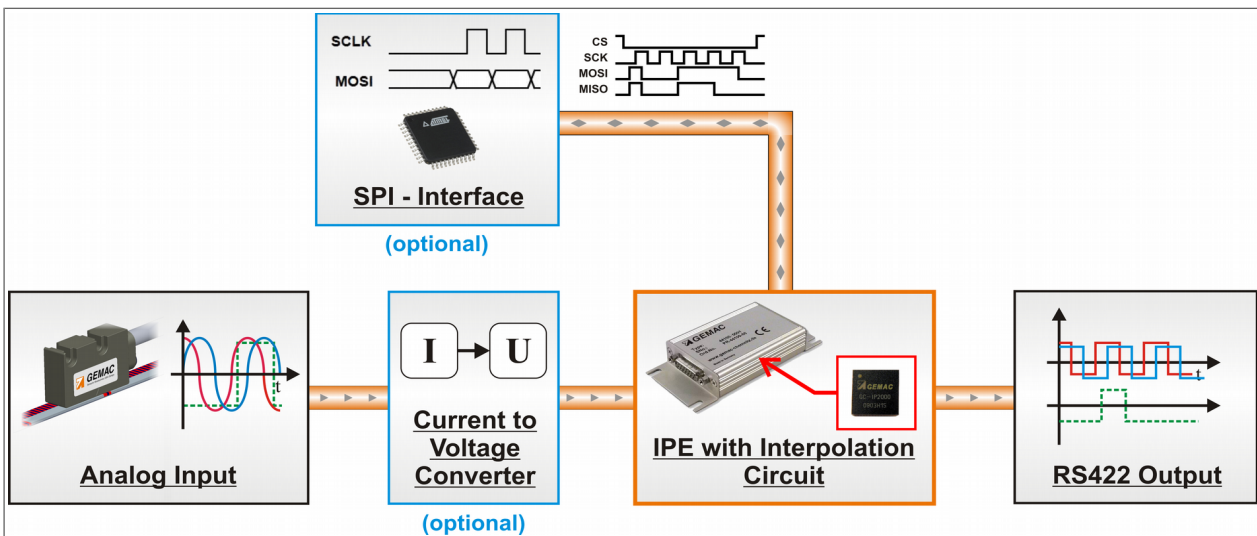

Figure 1: Block diagram

Table 1: Characteristics IPE40

Parameter	Function
Input signals	Sine- / Cosine- / reference signal Differential / single – ended Adjustable gain for 1 V _{pp} / 660 mV _{pp} / 530 mV _{pp} / 80 mV _{pp}
Output signals	90° - square wave (A/B/Z); TTL – and CMOS – compatible
Interpolation rate	40 / 32 / 20 / 16 / 8 / 4 edges per sine period
Input frequency	Maximum 1.2 MHz for Interpolation rates ≤ 20 Maximum 750 kHz for Interpolation rates = 32 Maximum 600 kHz for Interpolation rates = 40
Noise suppression	Adjustable hysteresis analogue Adjustable hysteresis digital Adjustable minimum edge distance at the output
Reference signal processing	Adjustable reference signal width at the output
Package	Strand casting housing 55 mm x 80 mm x 20 mm

2 Input Signals

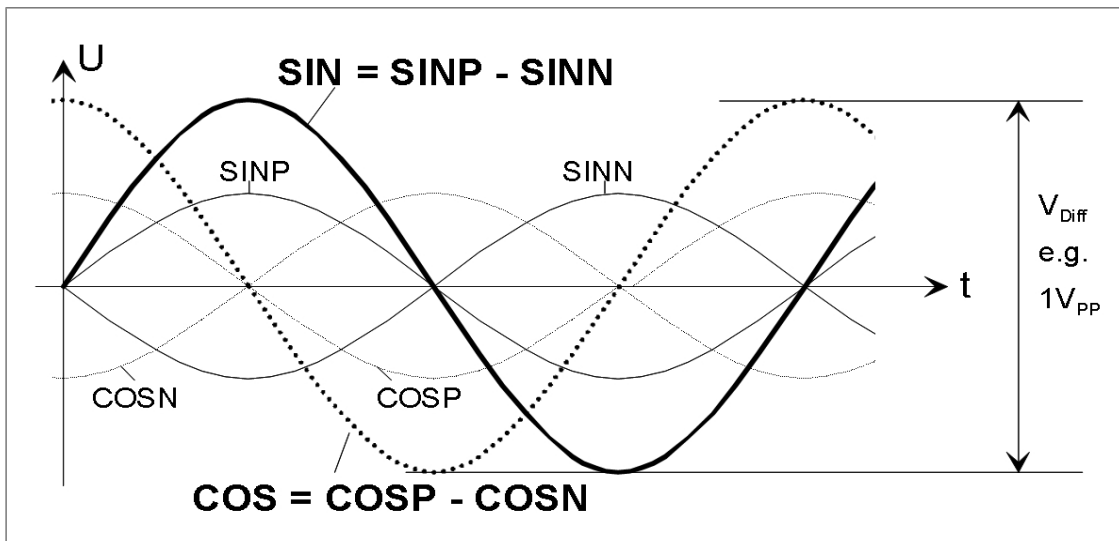

Figure 2: Input signals IPE40

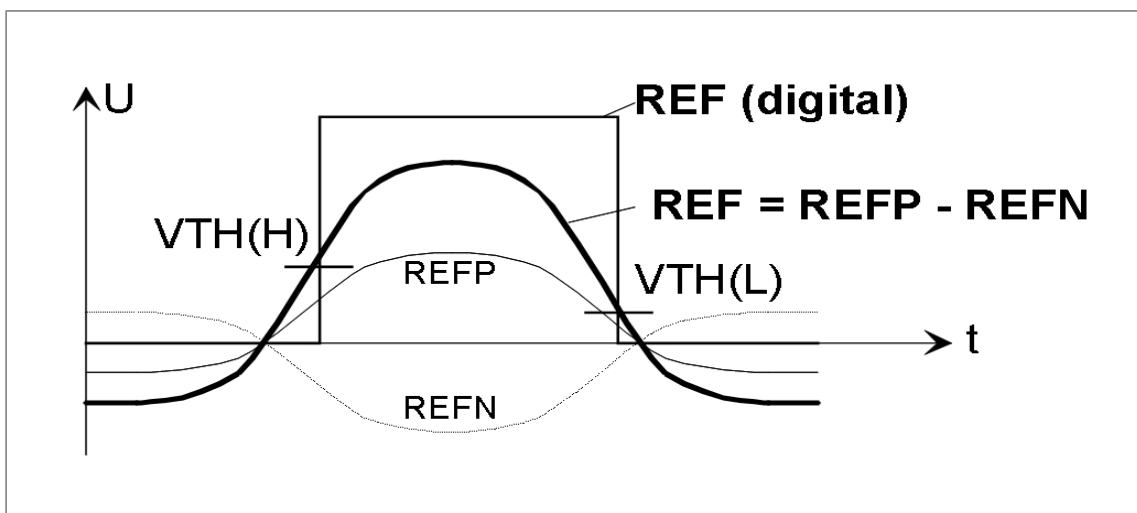

Figure 3: Reference Point Comparator

Table 2: Description Input Amplifiers

Parameter	Unit			
Switch GAIN	0	1	2	3
Input voltage for differential input (mV _{pp}) ¹⁾	333	40	265	500
Input voltage U _{Diff} nominal (mV _{pp})	666	80	530	1000
Input voltage range for U _{Diff} (mV _{pp})	400 – 800	60 – 100	320 – 640	600 – 1200

¹⁾ at each of the inputs SINP, SINN, COSP, COSN

3 Setting into Operation and Configuration

Before setting into operation the configuration of the IPE40 has to be checked. If the actual configuration differs from the default, the board has to be configured newly. It can be done by rotary switches and several jumpers.

The following text describes the configuration of the board.

The power supply voltage will be connected via the output connector X11. The soldering jumper has to be set as described at chapter 3 and the kind of operation can be chosen by the rotary switches S3 to S5. All the parameters can be found in chapter 4.

3.1 Meaning of the Connectors

Table 3: Connectors

Connector	Meaning
X 10	Sensor connector
X 11	Output connector RS 422

3.2 Meaning of the Jumpers

Table 4: Jumpers

Jumper	Meaning
J1, J3, J5	Termination resistor 120 Ω
J2, J4, J6	Single – ended sensors

3.3 Meaning of the Switches

Table 5: Switches

Switch	Meaning
S1	Digital Hysteresis
S2	Edge distance control
S3	Gain
S4	Configuration switch CFG0
S5	Configuration switch CFG1

4 Configuration of the Sensor Connection

4.1 Configuration of the Soldering Jumpers LJ1 – LJ6

The IPE40 is configured for voltage sensors by default. That means all the soldering jumpers LJ1 to LJ6 are open. Different gain settings can be set by using switch S3.

For connecting current sensors to the board the jumpers LJ1 to LJ6 have to be closed. The design was specified for 11 μ A output current.

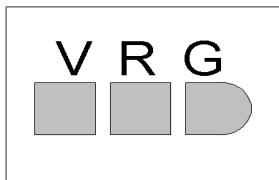

Figure 4: Soldering Jumper 7

If sensors without reference signal are used the behavior of the outputs can be configured with the soldering jumper LJ7. There is a choice of two modi. If **V – R** are connected a reference signal will be generated after every single sine period. In case of a connected between **R – G** the reference signal outputs are disabled. The unit is configured to reference point evaluation by default. So the jumpers are open.

4.2 Configuration of the Jumpers

Via the jumpers J1, J3 and J5 a 120 Ω termination resistor can be used in each channel. For using single – ended signals the jumpers J2, J4 and J6 have to be closed.

All jumpers are open by default. That means differential input signals without termination resistor.

5 Assignment and Adjustment of Operation – Modes

The mode of operation can be chosen by the rotary switches S3, S4 and S5.

5.1 Switch S3 – Gain Selection

Table 6: Gain Selection

Amplitude			GAIN Switch
Minimum	Nominal	Maximum	
0,6 V _{pp}	1,0 V _{pp}	1,2 V _{pp}	3 (Default)
320 mV _{pp}	530 mV _{pp}	640 mV _{pp}	2
50 mV _{pp}	80 mV _{pp}	100 mV _{pp}	1
400 mV _{pp}	666 mV _{pp}	800 mV _{pp}	0

5.2 Switch S4 and S5 – Interpolation Rate and Reference Pulse Width

For setting of the interpolation rate the rotary switches S4 (CFG0) and S5 (CFG1) can be used.

Table 7: Interpolation Rate and Reference Pulse Width

Output Z	IRATE	Square Wave Periods	Input Frequency	CFG0 Switch	CFG1 Switch
1 Increment	4 – fold	1 Period	≤ 1200 kHz	0	2
1 Increment	8 – fold	2 Periods	≤ 1200 kHz	3	2
1 Increment	16 – fold	4 Periods	≤ 1200 kHz	1	3
1 Increment	20 – fold	5 Periods	≤ 1200 kHz	2	3
1 Increment	32 – fold	8 Periods	≤ 750 kHz	0	3
1 Increment	40 – fold	10 Periods	≤ 600 kHz	3	3 (Default)
4 Increment	4 – fold	1 Period	≤ 1200 kHz	0	1
4 Increment	8 – fold	2 Periods	≤ 1200 kHz	3	1
4 Increment	16 – fold	4 Periods	≤ 1200 kHz	1	0
4 Increment	20 – fold	5 Periods	≤ 1200 kHz	2	0
4 Increment	32 – fold	8 Periods	≤ 750 kHz	0	0
4 Increment	40 – fold	10 Periods	≤ 600 kHz	3	0

Note:

The Interpolation rate (IRATE) is the number of increments in which the period of the input signals will be split. These are the number of edge changes at the output signals A and B. The number of square wave periods at these outputs is $\frac{1}{4}$ of the interpolation rate.

Note:

The reference pulse width is selectable between one and four increment. That means between $\frac{1}{4}$ an 1 period of the output signals A and B. The reference signal will be generated in case of an angle of 45° between sine and cosine and the difference voltage of the reference inputs **REFP** and **REFN** comes beyond the threshold. In case of selected reference pulse width one increment ($\frac{1}{4}$ period) the outputs A and B have to be HIGH at the same time.

5.3 Hysteresis

For eliminating the edge noise at lower input frequencies and at standstill an analogue and a digital hysteresis can be configured. The value of the analogue hysteresis is defined by the resistor at the pin RHYST and can not be changed. So a noise reduction for real time systems is possible without losing the synchronization between input and output signals. If the digital hysteresis at the pin RHYST is active, by switching S1, the switching of the outputs in case of static input signals is eliminated. All output signals are delayed for one angle increment (9 degrees resp. 11.25 degrees).

The following figure shows the consequences of the digital hysteresis in case of a change of direction at the example of an interpolation rate 16 edges per period.

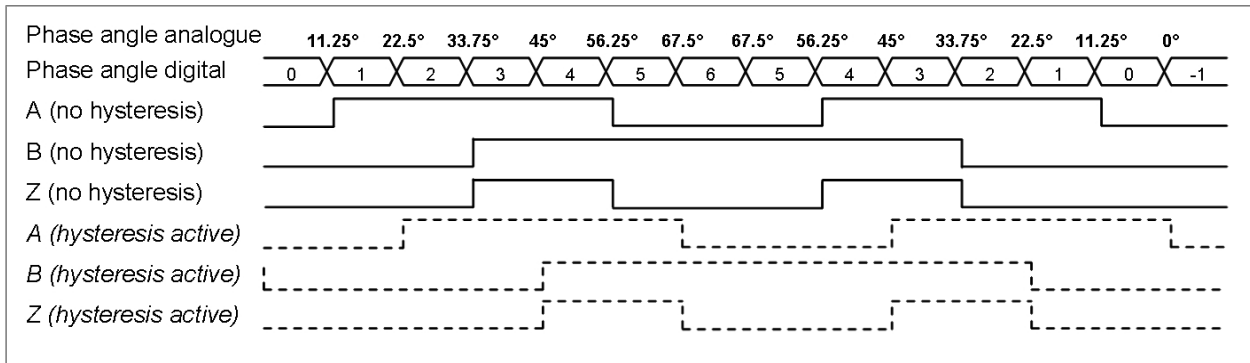

Figure 5: Digital Hysteresis

Table 8: Digital Hysteresis

Digital Hysteresis	
Deactivated	1/40 Sine period (IRATE = 10/5) (Default) 1/32 Sine period (IRATE = 8/4/2/1)

6 Edge Distance Control

The minimum distance t_{pp} at which the output signals A and B can switch is adjustable. After the switching of one of the outputs the following edge of the other signal occurs if the time t_{pp} has passed. So a following counter is able to count without error also in case of fast distortions. But there is no synchronization with a clock. Usually the edges are generated without a delay.

The maximum input frequency is defined by the minimum A/B – edge distance and the interpolation rate. It is limited by errors of the input signals. An exceeding of this frequency is signaled by the same time switching of the outputs A and B. If the input frequency is higher than three times of the selected maximum frequency the behavior of the outputs A, B and Z is not defined.

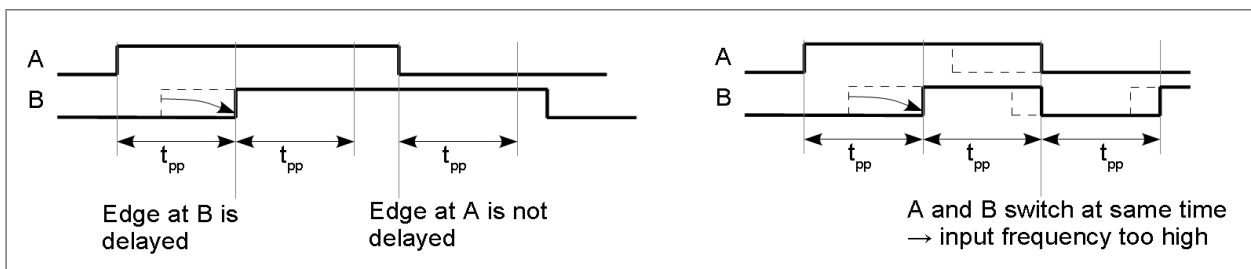

Figure 6: Minimum Edge Distance

The configuration of the minimum edge distance can be done by using the pin RT. A resistor to GND defines the time in the range of 30 ns to 1 ms. It has to be observed that this time can vary depending on exemplar and supply voltage. If the pin RT is connected to AVDD, the IC runs with the minimum A/B – edge distance of 33 ns (Mode TPP30). This time can vary between 26 ns and 40 ns.

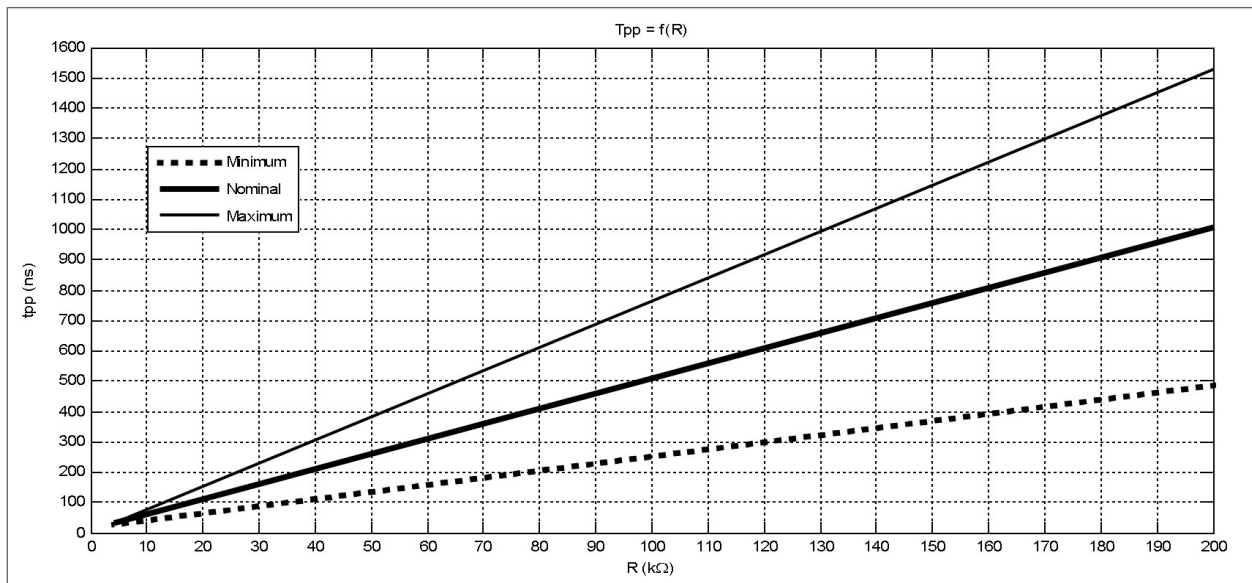

Figure 7: Configuration A/B – edge distance

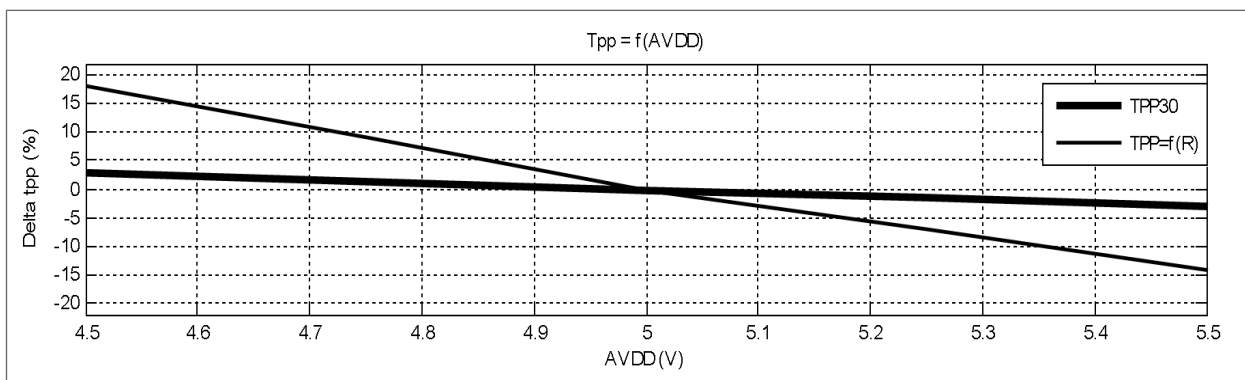
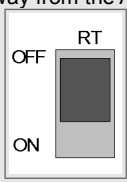
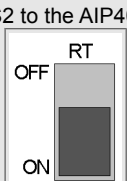

Figure 8: Dependence of the A/B – edge distance from the supply voltage

Table 9: Edge Distance Control

RT	Minimum Edge Distance t _{pp}		
	Minimum	Nominal	Maximum
S2 away from the AIP40 	26 ns	t _{pp} = f(R)	1700 ns
S2 to the AIP40 	26 ns	33 ns (Default)	40 ns

7 Connector Pinning

7.1 X10 – Measuring System Connector (Input) / X11 – Output RS422

Table 10: Signal input / Signal output

Signal input SUB – D 15-pin; female (X10)	
Pin No.	Signal
1	SINP
2	GND
3	COSP
4	+ 5 V
5	
6	
7	REFN
8	
9	SINN
10	GND
11	COSN
12	+ 5 V
13	
14	REFP
15	
16	

Signal Ooutput SUB – D 15-pin; male (X11)	
Pin No.	Signal
1	A +
2	GND
3	B +
4	+ 5 V
5	
6	
7	Z -
8	
9	A -
10	GND
11	B -
12	+ 5 V
13	
14	Z +
15	
16	

8 Parameters

8.1 Operation Conditions

Table 11: Operation Conditions

Symbol	Parameters	Min.	Typ.	Max.	Unit
VDD	Supply voltage	4,5	5,0	5,5 1)	V
I (AVDD)	Current consumption analogue		25	33	mA
I (DVDD)	Current consumption digital		3	5	mA
TOP	Operating temperature	- 40 1)		120	°C

1) Minimal temperature and maximal voltage are not allowed at the same time; If TOP < -15 °C then VDD(max) ≤ 5,25 V

8.2 Parameters Interpolation

Table 12: Parameters Interpolation

Symbol	Parameter	Min.	Typ.	Max.	Unit
fIP_40	Input frequency IR = 40, GAIN = GND/VCC/V0	0		600	kHz
fIP_32	Input frequency IR = 32, GAIN = GND/VCC/V0	0		750	kHz
fIP	Input frequency IR = 20/16/8/4, GAIN = GND/VCC/V0	0		1200	kHz
fIP_80 mV	Input frequency GAIN = open	0		250	kHz
EABS	Absolute angle error 1)		± 0,5	± 0,9	Increments
EDIFF	Differential angle error 1)		± 0,3	± 0,4	Increments
T _{pp(L)}	Minimum edge distance Pin RT = L	25		1700	ns
T _{pp(H)}	Minimum edge distance Pin RT = H	26	33	40	ns

1) Input voltage range 1 V_{pp}

8.3 Parameter Configuration / Parameters Digital

Table 13: Parameter Configuration / Parameters Digital

Symbol	Parameter	Min.	Typ.	Max.	Unit
VOH	Output voltage H 1)	80			% DVDD
VOL	Output voltage L 1)			0,4	V
I(DIG)	Output current digital 1)			4	mA
VTH(L – O)	Threshold voltage L / open 2)	7	10	13	% DVDD
VTH(O – V0)	Threshold voltage open / V0 2)	33	36	39	% DVDD
VTH(V0 – H)	Threshold voltage V0 / H 2)	87	90	93	% DVDD
V(CFG0)	Clamping voltage if open 2)	1,10	1,15	1,20	V
VTH(Rhyst)	Threshold voltage L/H am Pin RHYST		50		% DVDD
VTH(RT)	Threshold voltage L/H am Pin RT		85		% DVDD
R(Rhyst)	Configuration resistor hysteresis	47	160	160	kΩ
R(RT)	Configuration resistor edge distance	4		200	kΩ

1) Pins A, B, Z

2) Pins CFG0, CFG1, GAIN

9 Ordering Information

Table 14: Ordering Information

Product Type	Description	Article Number
IPE40	Interpolation Unit with GC-AIP40	PR-46900-00

10 Component mounting diagram

10.1 Component side

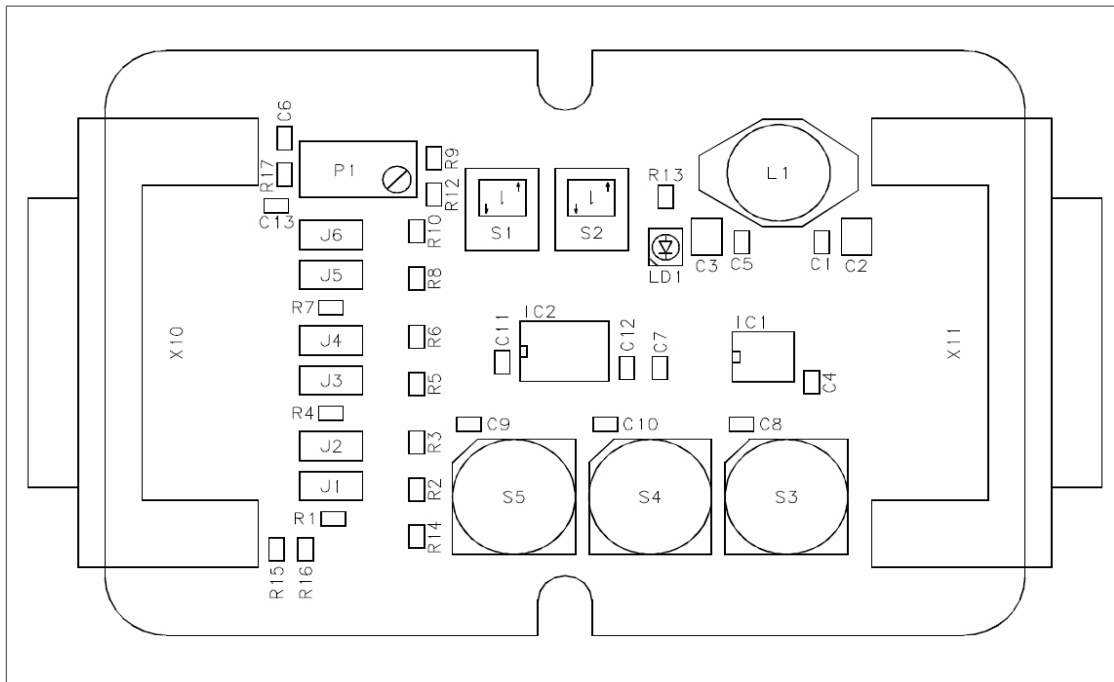

Figure 9: Component side

10.2 Dimensions

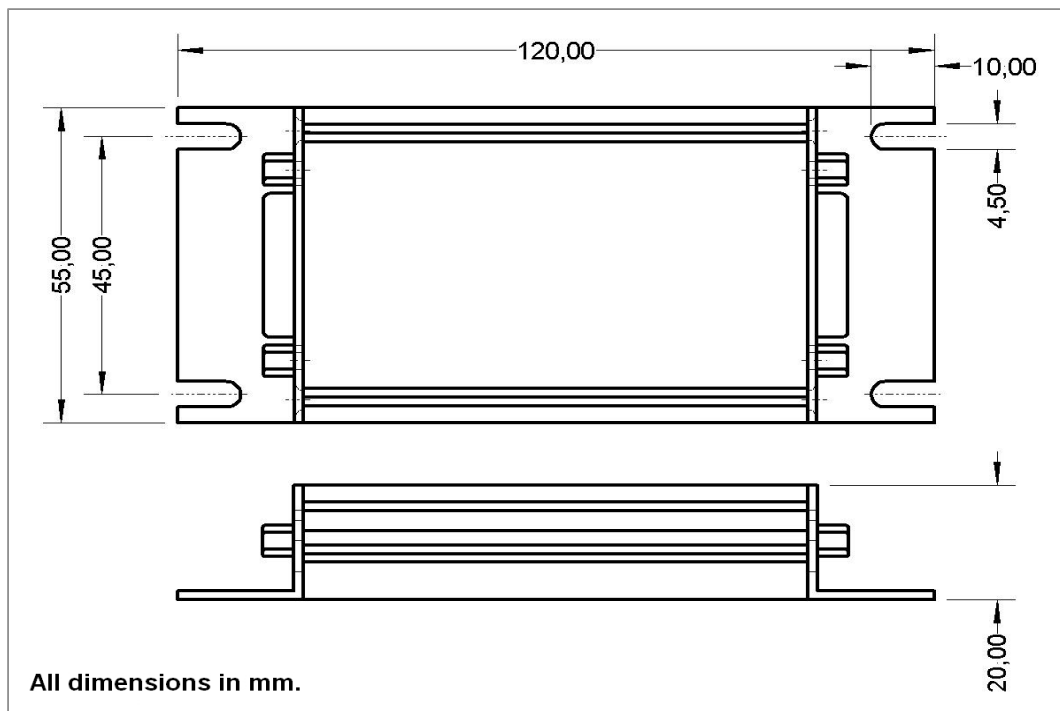

Figure 10: Dimensions

