



IPE2000-USB

User Manual

Version: 1.4
Date: 07/03/2017



Revision Overview

Date	Revision	Change(s)
20.08.2010	1.0	First version
04.08.2011	1.1	Update
30.01.2012	1.2	Appendix for special version
01.02.2012	1.3	Various changes and corrections
07/03/2017	1.4	change to new AMAC document layout

© Copyright 2018 AMAC ASIC- und Mikrosensoranwendung Chemnitz GmbH

Subject to change without prior notice.

Our policy is one of continuous improvement, and consequently the equipment may vary slightly from the description and specifications in this publication. The specifications, illustrations and descriptions provided in this documentation are not binding in detail. No part of this publication may be reproduced in any form, or by any means, without the prior written permission of AMAC ASIC- und Mikrosensoranwendung Chemnitz GmbH. All rights according to the law on copyright remain expressly reserved to AMAC ASIC- und Mikrosensoranwendung Chemnitz GmbH.

Table of Content

1 Overview.....	7
2 Features.....	8
3 Input Signals.....	9
3.1 Connection of a Measuring System.....	9
3.2 Description of the input amplifier.....	9
3.3 Signal correction.....	10
3.4 Reference Signal.....	10
4 Output Signals.....	11
4.1 Output Signals RS422.....	11
4.2 Error Signal.....	11
5 Interpolation Rate.....	12
5.1 Edge interval setting.....	12
5.2 Glitch filter.....	13
6 Specifications.....	13
7 Configuration of the Connectors.....	14
7.1 Signal input X1, female.....	14
7.2 Signal output X2, male.....	14
7.3 Signal output X2, male with ordered SPI – option.....	14
7.4 USB interface X3.....	15
7.5 Analogue output header X4.....	15
7.6 Extension header J1 and J2.....	16
7.7 LED.....	16
8 Configuration of the IP2000.....	17
8.1 Configuration with PC – program IP2k-Monitor.....	17
9 Ordering Information.....	17
10 Component Mounting Diagram.....	18
10.1 Component side.....	18
10.2 Dimensions.....	18
11 Notes.....	19

List of Tables

Table 1: Overview features.....	8
Table 2: Description of the input amplifier.....	9
Table 3: Signal correction.....	10
Table 4: Reference signal intern.....	10
Table 5: Configuration of the reference point.....	10
Table 6: Configuration of the interpolation rate.....	12
Table 7: Minimum edge interval.....	12
Table 8: Configuration of the hysteresis.....	13
Table 9: Specifications.....	13
Table 10: Signal input SUB – D 15-pin; female.....	14
Table 11: Signal output SUB – D 15-pin; male.....	14
Table 12: Signal output X2 with SPI.....	14
Table 13: USB interface X3.....	15
Table 14: Analogue test signal sine / cosine.....	15
Table 15: Extension header J1 and J2.....	16
Table 16: LED.....	16
Table 17: Ordering Information.....	17

List of Figures

Figure 1: Block diagram.....	7
Figure 2: Input signals single – ended.....	9
Figure 3: differential Input signals.....	9
Figure 4: Connection of a measuring system.....	9
Figure 5: Reference signal.....	10
Figure 6: Interpolation output signals.....	11
Figure 7: IP2k-Monitor.....	17
Figure 8: Component side.....	18
Figure 9: Dimensions.....	18

Terms, Definitions and Abbreviations

AVSS	–	ground analog (GND)
AN	–	square-wave signal A negative
AP	–	square-wave signal A positive
BN	–	square-wave signal B negative
BP	–	square-wave signal B positive
Cos	–	cosine signal (P = positive; N = negative)
DVDD	–	supply voltage digital (+ 5 V)
DVSS	–	ground digital (GND)
EN	–	error signal negative
EP	–	error signal positive
REF	–	reference signal (P = positive; N = negative)
RS422	–	EIA-422 (conduction-bound differential serial data transmission)
SENSVDD	–	supply voltage analog (+ 5 V)
Sin	–	sinusoidal signal (P = positive; N = negative)
SPI	–	serial peripheral interface
V0	–	mean voltage
Vpp	–	peak-to-peak voltage
ZN	–	square-wave signal Z negative
ZP	–	square-wave signal Z positive

1 Overview

The interpolation unit IPE2000 – USB was designed to increase the resolution for incremental position and angular measuring systems with sinusoidal output signals offset by 90°. The IC inside divides the signal period up to 2048 times. Incremental encoders with voltage interface can be connected directly. The interpolation unit may operate with both single – ended and differential input signals. The configuration of the board is possible either via EEPROM, or via USB. Optional it is possible to order a unit with serial interface and/or an active I/U converter to connect current encoders.

The input signals are subjected to an AMAC-specific internal gain and offset control. The phase displacement of the input signals can be corrected as well. The quality of the signals issued by the sensors is monitored in the internal interpolation circuit GC – IP2000.

The unit can be connected via the RS422 to a standard counter or controls. The internal power supply voltage is 5 VDC.

In addition, several build in functions of the interpolation circuit GC–IP2000 like switchable analogue filter or a digital hysteresis make the unit an ideal choice for use in control systems.

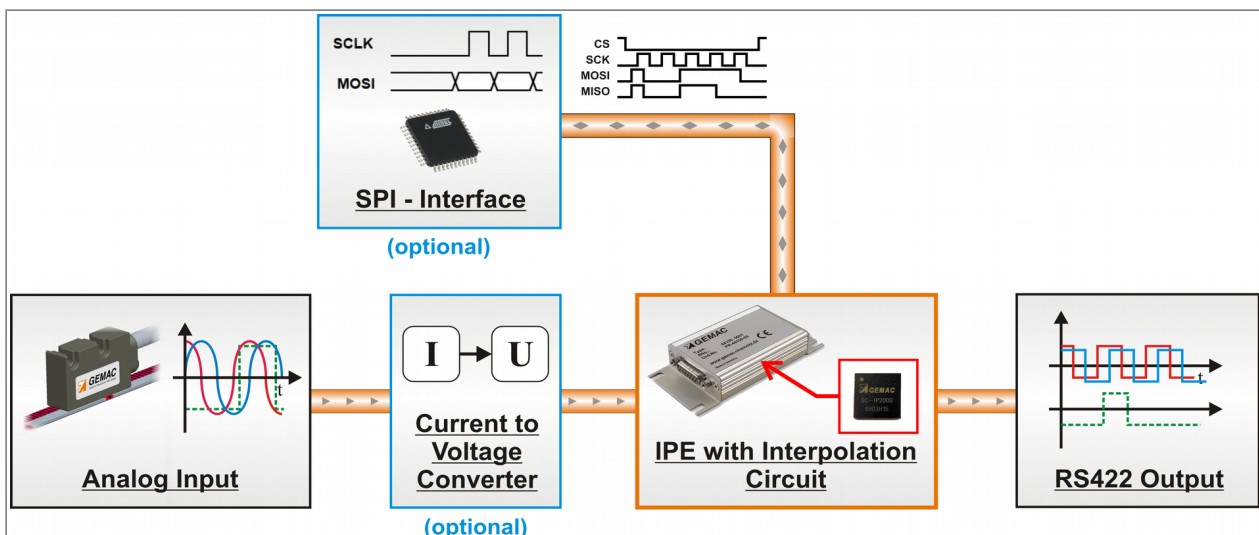

Figure 1: Block diagram

Note:

Detail description of all functions can be found in the data sheet of GC–IP2000.

2 Features

Analogue Part	
Analogue Input	<ul style="list-style-type: none"> - Sine / cosine / reference (index) signals; differential or single ended - Adjustable amplification for 1 V_{pp} / 500 mV_{pp} / 250 mV_{pp} / 75 mV_{pp} - Input frequency max. 260 kHz - Optionally: active I/U converter to connect current encoders
Digital Part	
Interpolation Rate	100 / 128 / 200 / 256 / 400 / 500 / 512 / 800 / 1000 / 1024 / 1600 / 2000 / 2048
Output Signals	<ul style="list-style-type: none"> - 30-bit counter value via USB, serial interface (SPI) optional - Up to 500000 measurement values per second - 90° square-wave sequences (A/B/Z) - Error signal - Auxiliary signals for sensor adjustment - RS422 interface - 5V
Signal Correction	<ul style="list-style-type: none"> - AMAC-specific digital controller for the offset, control range ±10 % of standard amplitude - AMAC-specific digital controller for the amplitude, control range factor 0.5 ... 1.5 - Digital potentiometer with 40 steps for phase correction; selectable range ±5° or ±10° - LED control signal
Possibilities of configuration	Either: via USB, EEPROM or, if the option is ordered, via serial interface (SPI)
Optional SPI (internal interface)	<ul style="list-style-type: none"> - Compatible to the standard SPI: 16-bit, MSB first - SPI clock up to 25 MHz - For configuration and measuring value output; not required for trivial systems - 5V or 3.3V interface
Miscellaneous	
Suppression of disturbances	<ul style="list-style-type: none"> - Selectable analogue noise filter - Digital hysteresis for suppression of the edge noise at the output
Adaptation of IC to subsequent devices	<ul style="list-style-type: none"> - Adjustable minimum edge interval at the output - Behaviour of IC in case of sensor error can be programmed - Adjustable width zero signal Z of ¼ or 1 period A/B

Table 1: Overview features

3 Input Signals

The input signals of the IPE2000 – USB are analogue voltages (sine / cosine), which have a sine – shaped dependency on the measured value (position or angle). The phase shift between those two analogue voltages is 90°, related to one period of the scale. A third input signal serves the zero or reference point of the scale as reference signal for determining. All the three input signals are processed as differential or single – ended signals.

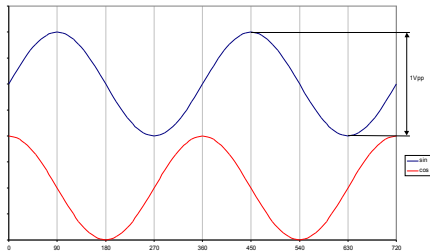

Figure 2: Input signals single – ended

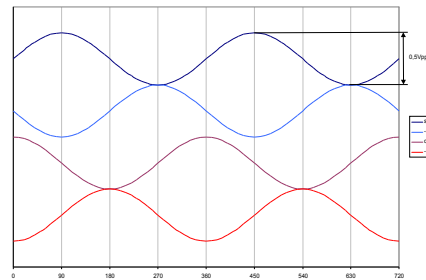

Figure 3: differential Input signals

3.1 Connection of a Measuring System

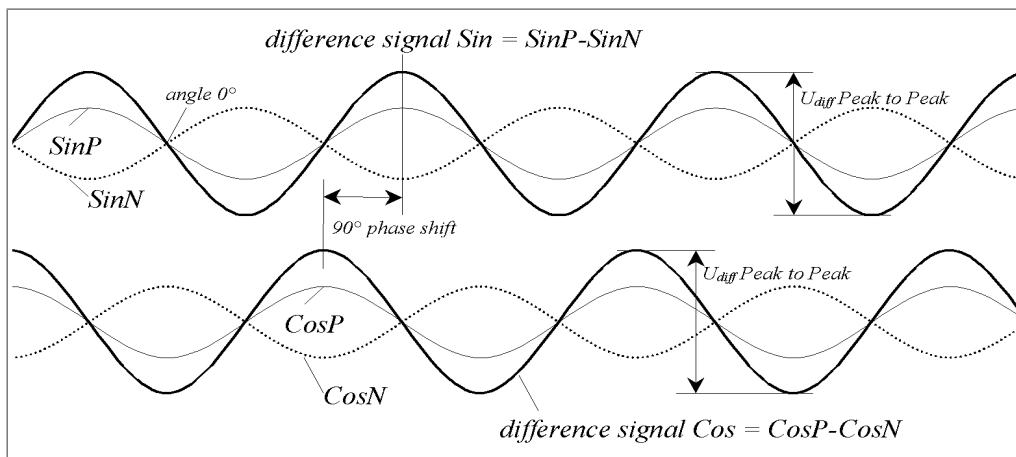

Figure 4: Connection of a measuring system

3.2 Description of the input amplifier

The gain can be set through the CFG1 – register. (See also data sheet GC – IP2000)

Table 2: Description of the input amplifier

Description	Parameter			
	VSS(A)	VDD(A)	V0	open
CFGGAIN	VSS(A)	VDD(A)	V0	open
Configuration bits CFG1 – GAIN (1:0)	00	01	10	11
Gain factor (nominal)	1	2	4	12,5
Input voltage for differential supply (mVpp) 1)	500	250	125	37,5
Input voltage UDiff nominal (mVpp)	1000	500	250	75
Input voltage range for UDiff (mVpp)	600 – 1200	300 – 600	150 – 300	45 – 90
Lower switching point – reference comparator, nominal (mV)	+ 43	+ 21	+ 11	+ 3
Upper switching point – reference comparator, nominal (mV)	-19	-9	-5	-1
Bit CFG1 / LPF	recommended	recommended	recommended	necessary

1) at each of the inputs SINP, SINN, COSP, COSN

3.3 Signal correction

The input signals are subjected to an AMAC-specific internal gain and offset control. The amplitudes are controlled in the range between 60 % and 120 % of the standard amplitude. The control range for the offset of the two signals is $\pm 10\%$ of the nominal amplitude. The phase shift of the input signals can be adjusted statically by the internal potentiometer in a range of $\pm 5^\circ$ or $\pm 10^\circ$.

There are two measuring points X4 Pin 1 (SMON) and X4 Pin 2 (CMON) for testing the signals. The signal at each of those measuring points should have an amplitude of 2.1 V and an offset of ± 0.21 V referring to ground.

Table 3: Signal correction

Parameter	as a percentage referred to the nominal amplitude (PEAK – PEAK)	as a percentage referred to the ADC maximum (PEAK – PEAK)	in mV referred to the standard signal (1 V _{pp})	in V the pin SMON or CMON
Maximal value at the input	150	100	1500	3.15
Nominal value of the input signal	100	66.7	1000	2.10
Guaranteed control range for the amplitude	60 ... 120	40 ... 80	600 ... 1200	1.26 ... 2.52
Setting range of the amplitude controller	56 ... 168 ¹⁾	38 ... 112 ¹⁾	560 ... 1680 ¹⁾	1.18 ... 3.53 ¹⁾
Vector monitoring ²⁾	30	20	300	0.63
Guaranteed control range for the offset (sensor)	± 10	± 6.7	± 100	± 0.210
Setting range of the offset controller	± 25	± 17	± 250	± 0.525

¹⁾ The setting range for the amplitude is greater than the control range of the ADC. Therefore, the upper limit of the setting range cannot be fully utilised for the analogue signals.

²⁾ An aggregate signal from sine and cosine is monitored.

3.4 Reference Signal

The reference signal of measuring systems is typically called reference, index point or zero point signal. The reference signal is detected, if the difference of the signals at the input REFP and REFN is greater than the positive hysteresis voltage V_{TH(L)}.

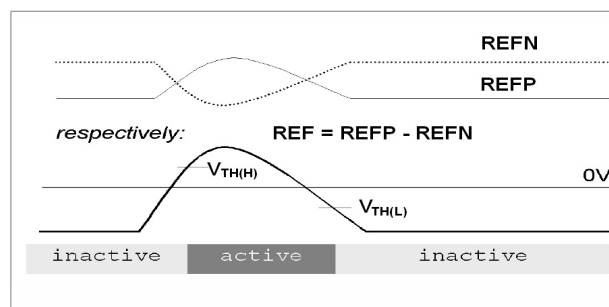

Figure 5: Reference signal

Note:

The reference point processing in the IPE2000 – USB can be deactivated in the internal configuration if no detection of the reference signal is needed.

Table 4: Reference signal intern

Register value CFG1 / DISZ	Meaning
0	Reference signal at the output active
1	Reference signal at the output inactive

Note:

The shape of the Z – signal on the output of the IPE2000 – USB can be adapted for different applications in the configuration of the interpolation circuit. Is one increment selected for the width of the Z – signal, the Z – Impuls on the output corresponds exactly one quarter of the period duration of the signals A and B. The Z – Impuls extends over a whole period when four increments are selected.

Table 5: Configuration of the reference point

Register value CFG1 / Z4	Meaning
0	1 increment = ¼ period
1	4 increments = 1 period

4 Output Signals

4.1 Output Signals RS422

The output signals are phase shifted square wave sequences (known by incremental measuring transducers). They can be counted in a single or quadruple way. A synchronous Z – impuls will be generated when the angle of 45° (refer also to Figure 4) is passed through and when the analogue differential input voltage between REFP and REFN exceeds the positive comparator hysteresis level. If the differential input voltage is permanently above this level, the reference pulse will be generated once during every signal period. The output signals are differential AP – AN, BP – BN, ZP – ZN.

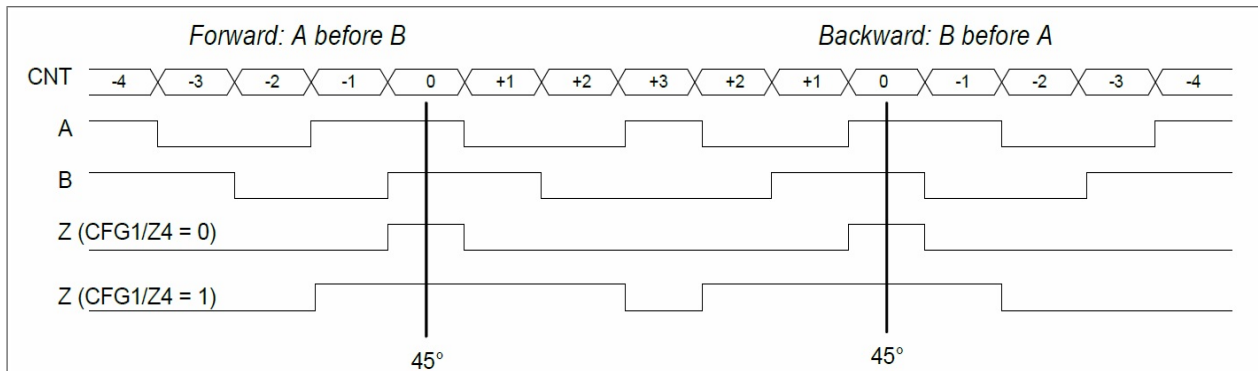

Figure 6: Interpolation output signals

Note:

The Signals A, B and Z are offset in time by 1 increment if the digital hysteresis is activated.

4.2 Error Signal

An error signal will be generated if the input signals are plausible no longer. The error signal will also be generated if the input frequency is so high that the square-wave signals are unable to follow, and/or when the maximum input frequency is exceeded. It is recommended to use the error signal for data processing.

Note:

If the error signal was detected, the current measuring results and the following results should be discarded. Following elimination of the cause of the error and a reset of the error bit, the reference point has to be passed by for absolute value measurements once again!

5 Interpolation Rate

Possible interpolation rates (IRATE) which can be selected are 2048, 2000, 1600, 1024, 1000, 800, 512, 500, 400, 256, 200, 128 or 100. The term 'interpolation rate' is here understood as the number of increments into which the sinusoidal / cosinusoidal period of the input signals is divided.

Table 6: Configuration of the interpolation rate

Interpolation rate	CFG1 – IR(3:0)
2000	0000 (0)
1600	0001 (1)
1000	0010 (2)
800	0011 (3)
500	0100 (4)
400	0101 (5)
200	0110 (6)
100	0111 (7)
2048	1000 (8)
1024	1001 (9)
512	1010 (10)
256	1011 (11)
128	1100 (12)
1000	1101 (13)
1000	1110 (14)
1000	1111 (15)

5.1 Edge interval setting

The minimum time interval t_{pp} at which the output signals A,B and Z may switch can be adjusted in binary steps between $1/f_{OSZ}$ and $128/f_{OSZ}$. This function can be used to restrict the bandwidth of the IPE2000 – USB for slow RS422 – Counters.

Table 7: Minimum edge interval

Min. edge interval tpp	Register CFG1 – TPP(2:0)	Pin CFGTPP
$1/f_{OSZ}$	000 (0)	VSS
$2/f_{OSZ}$	001 (1)	VDD
$4/f_{OSZ}$	010 (2)	V0
$8/f_{OSZ}$	011 (3)	open
$16/f_{OSZ}$	100 (4)	
$32/f_{OSZ}$	101 (5)	
$64/f_{OSZ}$	110 (6)	
$128/f_{OSZ}$	111 (7)	

5.2 Glitch filter

To suppress the edge noise of the output signals at low input frequencies and standstill, a digital hysteresis can be activated for the signals A, B and Z. This prevents switching of the outputs with static input signals. In this case, all output signals are delayed by one increment.

Pin CFGFILT	CFG1 – DHE	CFG1 – Bit 11	Digital hysteresis
VSS	0	1	Don't use this configuration
VDD	1	1	Don't use this configuration
V0	0	0	deactivated
open	1	0	activated

Table 8: Configuration of the hysteresis

6 Specifications

Table 9: Specifications

Characteristic values				
Recommended Operating Conditions	Min.	Nom.	Max.	Unit
Supply voltages	4.75 (4.5) ¹⁾	5.0	5.5	V
Supply current		90		mA
Internal interface voltage		3.3 / 5.0		V
Mid – voltage V _{0BUF}	2.1	2.25	2.4	V
Output Current on V _{0BUF}			30	mA
Operating case temperature	- 20		80	°C
Analog Input Specifications	Min.	Nom.	Max.	Unit
Input frequency			110	kHz
Phase offset between SIN and COS		90		°
Peak to Peak input voltage SINN ↔ SINP / COSN ↔ COSP	0.08	1.0	1.2	V _{pp}
Phase deviation	4.5 / 9	5 / 10	9 / 11	°
Oscillator frequency		25		MHz
Interpolation	Min.	Nom.	Max.	Unit
Interpolation Rates	100 / 128 / 200 / 256 / 400 / 500 / 512 / 800 / 1000 / 1024 / 1600 / 2000 / 2048			
Minimum interval time A / B – Signals	1 / fosz		128 / fosz	ns
Interpolation accuracy		± 0.7		
Propagation delay square – wave outputs (A / B / Z)	155 / fosz		187 / fosz	ns
Other characteristics	Extruded aluminium housing			
Degree of protection	IP20			
Connector	SUB – D, 15-pin			
Dimensions	55 mm x 80 mm x 20 mm			

¹⁾ The control ranges and the interpolation accuracy are limited between 4.5 V and 4.75 V.

7 Configuration of the Connectors

If IPE2000 – USB is used without SPI – option it is necessary to open the unit for configuration. This can be done by open the screws at both sides. The cover can be lift off now.

7.1 Signal input X1, female

Table 10: Signal input SUB – D 15-pin; female

Pin	Name	Direction	Meaning
1	SINP	Input	Encoder signal sine positive
2	AVSS	Output	Encoder ground
3	COSP	Input	Encoder signal cosine positive
4	SENSVDD	Output	Encoder power supply 5V
5	–	–	–
6	–	–	–
7	REFN	Input	Encoder signal reference negative
8	–	–	–
9	SINN	Input	Encoder signal sine negative
10	AVSS	Output	Encoder ground
11	COSN	Input	Encoder signal cosine negative
12	SENSVDD	Output	Encoder power supply 5V
13	–	–	–
14	REFP	Input	Encoder signal reference positive
15	–	–	–

7.2 Signal output X2, male

Table 11: Signal output SUB – D 15-pin; male

Pin	Name	Direction	Meaning
1	AP	Output	Square wave Output A positive
2	DVSS	Input	Unit power supply ground
3	BP	Output	Square wave Output B positive
4	DVDD	Input	Unit power supply 5V
5	EP	Output	Error Output E positive
6	–	–	–
7	ZN	Output	Square wave Output Z negative
8	nTRGIN	Input with pullup	Trigger signal input; falling edge active
9	AN	Output	Square wave Output A negative
10	DVSS	Input	Unit power supply ground
11	BN	Output	Square wave Output B negative
12	DVDD	Input	Unit power supply 5V
13	–	–	–
14	ZP	Output	Square wave Output Z positive
15	EN	Output	Error Output E negative

7.3 Signal output X2, male with ordered SPI – option

Table 12: Signal output X2 with SPI

Pin	Name	Direction	Meaning
1	MISO	Output	SPI MISO
2	DVSS	Input	Unit power supply ground
3	SEN	Output	SPI SEN
4	DVDD	Input	Unit power supply 5V
5	EP	Output	Error Output E positive not used
6	–	–	–
7	ZN	Output	Square wave Output Z negative not used
8	nTRGIN	Input with pullup	Trigger signal input; falling edge active
9	MOSI	Input	SPI MOSI
10	DVSS	Input	Unit power supply ground
11	BN	Output	SPI SCK
12	DVDD	Input	Unit power supply 5V
13	–	–	–
14	ZP	Output	Square wave Output Z positive not used
15	EN	Output	Error Output E negative not used

7.4 USB interface X3

Table 13: USB interface X3

Pin	Name	Meaning
1	+ USB	+ 5 V
2	USBD -	Data -
3	USBD +	Data +
4	ID	–
5	- USB	GND

7.5 Analogue output header X4

Table 14: Analogue test signal sine / cosine

Pin	Name	Direction	Meaning
1	SMON	Output	analogue test signal sine
2	CMON	Output	analogue test signal cosine
3	GND	Input	analogue ground for measuring

7.6 Extension header J1 and J2

It is possible, to use the IPE2000 – USB in conjunction with an external I/U – converter (made to order) or customer specific electronics connected via extension header J1 and J2. All sensor signals, the mid – voltage V0 and the analogue supply voltage AVDD are available. J1 serves as output of IPE2000 – USB (input of external electronics) and J2 serves as input of IPE2000 – USB (output of external electronics).

Table 15: Extension header J1 and J2

Pin	Name	Direction	Meaning
1	AVDD	J1 / J2: Output	analogue supply voltage 5V (output)
2	AVDD	J1 / J2: Output	analogue supply voltage 5V
3	V0BUF	J1 / J2: Output	Buffered mid-voltage of GC-IP2000; Maximum output current of signal V0BUF is 30mA
4	COSP	J1: Output; J2 Input	Encoder signal cosine positive
5	COSN	J1: Output; J2 Input	Encoder signal cosine negative
6	SINP	J1: Output; J2 Input	Encoder signal sine positive
7	SINN	J1: Output; J2 Input	Encoder signal sine negative
8	REFP	J1: Output; J2 Input	Encoder signal reference positive
9	REFN	J1: Output; J2 Input	Encoder signal reference negative
10	AVSS	J1 / J2: Output	analogue ground
11	AVSS	J1 / J2: Output	analogue ground

7.7 LED

Table 16: LED

LED	Value	Meaning
Sensor monitor LD1 LD2	red (LD2 off)	Sensor adjustment necessary / Sensor not connected
	green (LD1 off)	Sensor signals valid
Power LED LD3	Off	IPE2000-USB not working
	green	IPE2000-USB working

8 Configuration of the IP2000

8.1 Configuration with PC – program IP2k-Monitor

After the reset of the IC GC – IP2000, all registers are initialised with their default values.

If an IPE2000 – USB unit with SPI – option is used, it should be noted that during the whole RESET sequence the Pin MISO / nWAIT is maintained at L level. Subsequently, the configuration register can be modified via USB or if the SPI – option was ordered via the serial interface SPI. Therefore it is recommended to use the program “IP2k-Monitor” which is downloadable at www.amac-chemnitz.de.

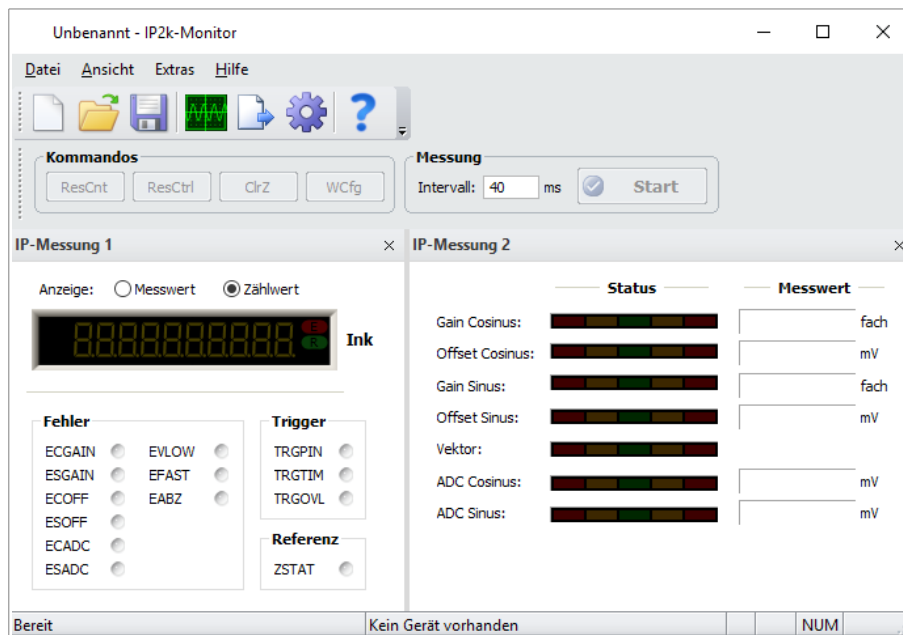

Figure 7: IP2k-Monitor

Attention:

- The hardware – address on the dialogue bar is not selectable and should always be 0x00 because the IPE2000 – USB can't be used with another hardware – address.
- The checkbox for LEDMODE should always be empty because the LED Control Mode is not supported from the IPE2000 – USB. If the box is checked and the IPE2000 – USB was programmed with this configuration, LD1 and LD2 will not work correctly.
- Button SETHWA at the Expert View is without function because the IPE2000 – USB can't be used with another hardware – address than 0x00.

9 Ordering Information

Table 17: Ordering Information

Product Type	Description	Article Number
IPE2000 – USB	Interpolation Unit with IP2000 (standard configuration)	PR-44100-10

10 Component Mounting Diagram

10.1 Component side

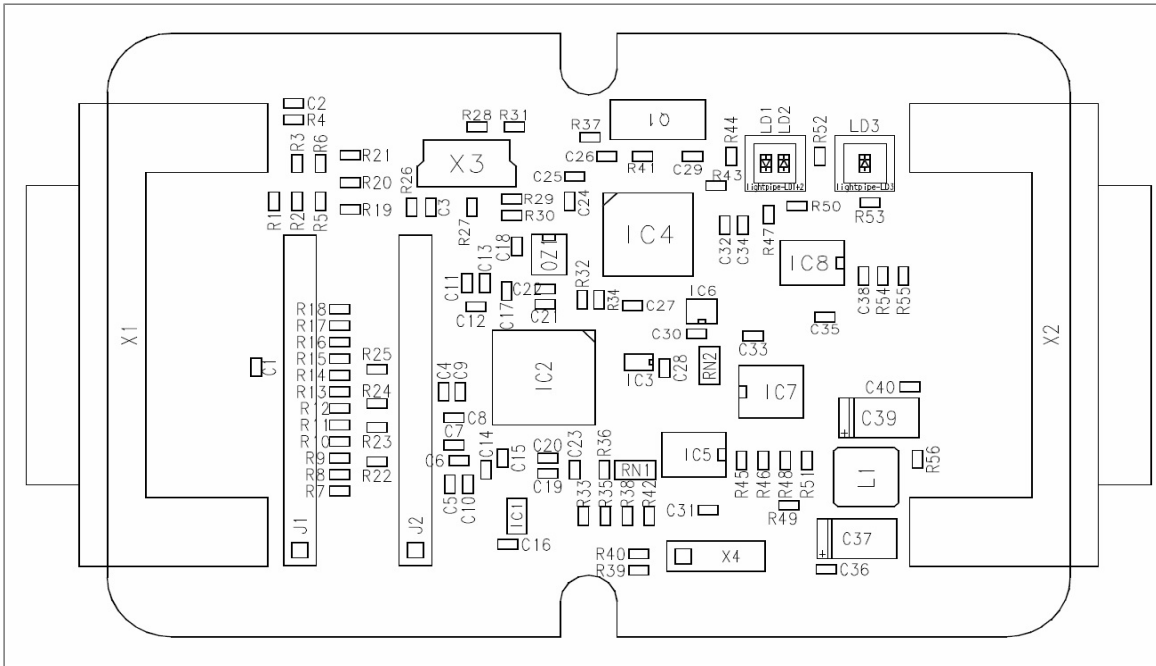

Figure 8: Component side

10.2 Dimensions

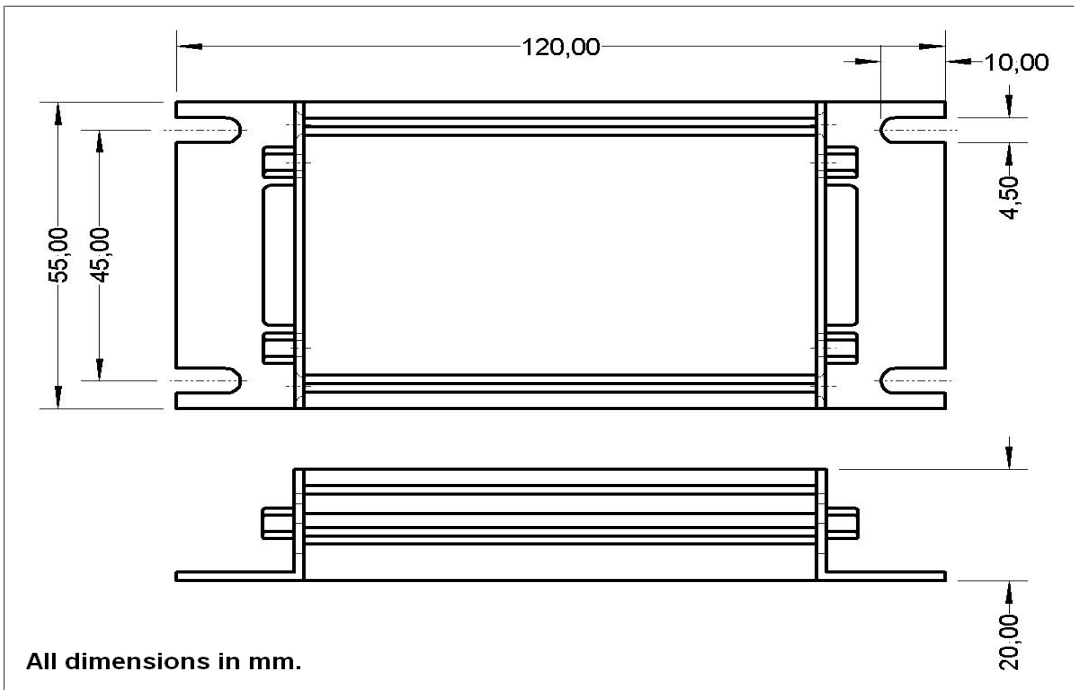

Figure 9: Dimensions

